

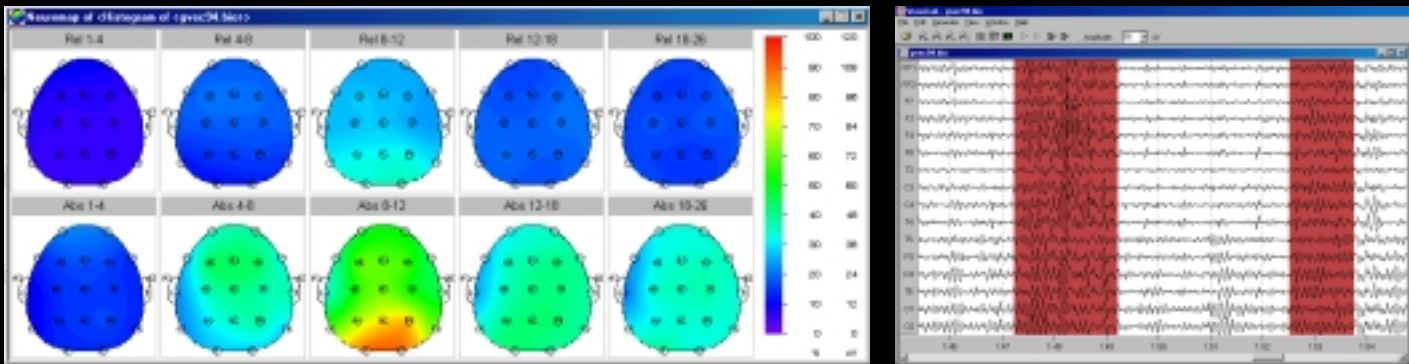

MS-1000 Reference Manual



NOLAN

NOLAN COMPUTER SYSTEMS



MS - 1000
Hardware Reference Manual

Release 1.0

NOLAN
NOLAN COMPUTER SYSTEMS

Copyright and Trademark Notice

Copyright © 1997 - 2000 by Nolan Computer Systems (NCS). All rights reserved. No part of this publication may be reproduced, stored in a retrieval system, or transmitted in any form or by any means, electronic, mechanical, photocopying, recording, or otherwise, without the prior written permission of NCS. The information contained herein is designed only for use with the Mindset MS-1000 EEG System. NCS is not responsible for any use of this information as applied to other products.

Mindset is a trademark of Nolan Computer Systems. MS-DOS, Microsoft, Windows, Windows 95, 2000 and Windows NT are trademarks (or registered trademarks) of Microsoft Corporation. Other product names used herein are for identification purposes only and may be trademarks of their respective holders.

FCC Compliance Statement for Use Within the United States

The Mindset MS-1000 generates and uses radio frequency energy and may cause interference to radio and television reception. It has been type tested and found to comply with the limits for a Class B computing device in accordance with the specifications for Subpart J of Part 15 of the FCC rules. These specifications provide reasonable protections against interference in a residential installation. However, there is no guarantee that interference of the Mindset MS-1000 will not occur in a particular installation. To ensure compliance of the Mindset MS-1000 to FCC rules, a shielded interface cable must be used between the Mindset MS-1000 and the computer. If the Mindset MS-1000 causes interference to radio or television reception, which can be determined by turning the Mindset MS-1000 on and off, the user can try to correct the interference by one or more of the following means:

1. Reorient the receiving antenna.
2. Reorient the Mindset MS-1000's position with respect to the receiver.
3. Plug the Mindset MS-1000 into a different power outlet so that it and the receiver are on different branch circuits.

If necessary, the user should consult the dealer or an experienced radio/television technician for additional suggestions. The user may find the following booklet helpful: "How to Identify and Resolve Radio-TV Interference Problems". It is available from the U. S. Government Printing Office, Washington, D.C. 20402, stock number 004-000-00345-4.



DO NOT PROCEED BEFORE READING

NCS assumes no liability for any direct, indirect, incidental or consequential damages resulting from the use of this product.

Mindset is not FDA approved. No statement contained in this document and no information provided by Nolan Computer Systems (NCS) should be construed as a claim or representation that this product is intended for use in the diagnosis, cure, mitigation, treatment or prevention of disease or any other condition.

Exercise extreme care in handling all connections to human subjects, including electrodes and grounding straps. Follow all guidelines provided by the manufacturer of your electrode system. If you are unsure about any connection to a human subject, stop and seek proper guidance.

Mindset conforms to its operational and design specifications only if operated and maintained in accordance with provided instructions. Do not use this product if you suspect malfunction or observe any wear or damage.

Backup all of your data before installing any new hardware, software or peripheral. After installation, routinely backup all data. NCS is not responsible for lost or damaged data.

Turn off and unplug Mindset before cleaning. See “Cleaning Mindset” for more information. Do not spill liquid on Mindset. Do not, under any circumstances, allow liquid to touch the input jacks or Expansion Connector.

Do not open the Mindset enclosure. There are no user serviceable parts. Opening the Mindset enclosure will void your warranty and may expose you to hazardous electrical potentials.

Do not operate the Mindset MS-1000 in any of the following circumstances:

- In an ungrounded power outlet.
- In a power outlet shared with heavy-load equipment such as photocopiers, air-conditioners, laser printers or large computer monitors.
- If any liquid has entered the enclosure or is in close proximity to the power or interface cables.
- During an electrical storm. Whenever there is lightning in the area, disconnect Mindset’s power cable from the power outlet.
- In direct sunlight or in any environment where the enclosure could become heated beyond 90° F. This will impair proper cooling and may cause permanent damage to Mindset.

How To Use This Manual

This manual addresses the installation and proper use of the Mindset MS-1000. You must refer elsewhere for general EEG information and for guidance in EEG analysis. The following symbols are used to draw your attention to information that is particularly important:



Critical information. Do not proceed before reading.



Important advisory information.



Information pertaining to electrical and electric shock issues.



General advisory information.

Please read all sections thoroughly before attempting to use this product.

Table of Contents

Chapter 1: Getting Started	1
Contents of the Mindset package and system requirements.	
Chapter 2: Hardware Installation	2
Configuring and connecting the Mindset MS-1000 to your computer.	
Configuring electrode connections.	
Chapter 3: Achieving Good Recordings	12
Using Mindset to obtain good EEG data.	
Minimizing artifact data contamination.	
Appendix I	16
Technical support and product service information.	
Contacting Aquathought Labs.	
Appendix II	18
Cleaning Mindset.	
Appendix III	19
Mindset MS-1000 specifications.	
Appendix IV	22
Using an Electro-Cap with Mindset.	
Appendix V	25
Additional SCSI Issues.	

Chapter 1: Getting Started

Contents of the Mindset Shipping Carton

Your Mindset MS-1000 comes packaged in a sturdy shipping carton. If possible, retain this carton and all packing materials. If service becomes necessary, Mindset should be returned in the original carton. Inspect the carton for evidence of shipping damage or mishandling. If you discover such evidence, notify your carrier and reseller from whom you purchased Mindset.

Verify that the following items are included in the carton. If any items are missing, contact the reseller from whom you purchased Mindset.

1. Mindset MS-1000 device
2. Linked-Ear B Inputs Montage Selector
3. Power Supply
4. Power Cable
5. SCSI Terminator
6. CD-ROM Disc containing the Mindset software
7. Warranty Registration Card.

Please register your Mindset MS-1000 so that we may keep you up-to-date about the latest product improvements, expansion options and special offers.

System Requirements

To use the Mindset hardware and software, your computer must have:

1. A Pentium class or compatible CPU. For optimum realtime performance, a 133MHz Pentium (or faster) is recommended.
2. Windows 95, 98, 2000 or Windows NT.
3. At least 8 megabytes of RAM.
4. At least 20 megabytes of available hard drive space.
5. At least a VGA class video adapter (an accelerated graphics adapter greatly enhances realtime neuromapping screen performance).
6. A fully Windows compliant SCSI adapter and cable.



Many SCSI adapters on the market do not provide optimal performance in realtime data acquisition. For the best results, contact your distributor or refer to the enclosed document "SCSI Solutions" for a list of SCSI adapters that are known to perform well with Mindset.

Chapter 2: Hardware Installation

Installing the MS-1000 Hardware

Use the following illustrations to help identify the main features of the MS-1000 hardware.

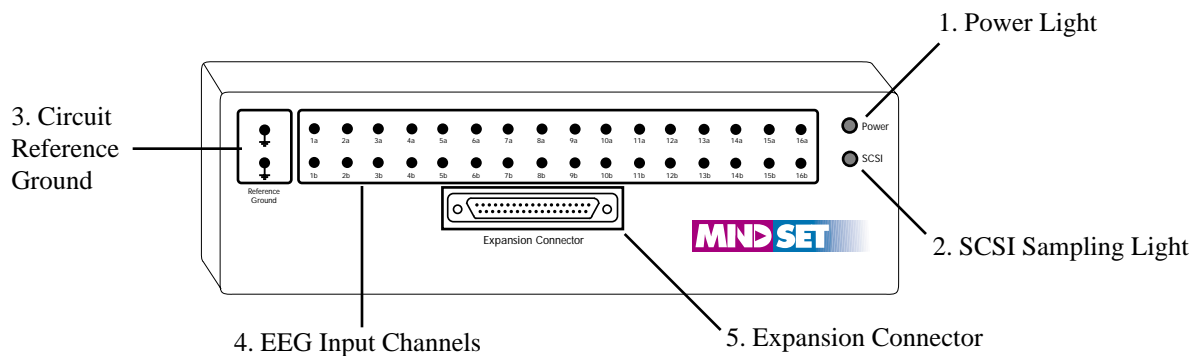

Figure 2.1 - Mindset Front View

<u>Feature</u>	<u>Description</u>
1. Power Light	Indicates when the Mindset instrument is on.
2. SCSI Sending Light	Indicates when Mindset is sampling and sending data to your computer.
3. Circuit Reference Ground	Used for calibration and expansion options. Not used for general EEG analysis.
4. EEG Input Channels	16 differential EEG channels marked 1- 16. “a” and “b” represent the differential inputs for each channel.
5. Expansion Connector	Used to attach the included Linked-Ear B Inputs referential montage selector and for future expansion.

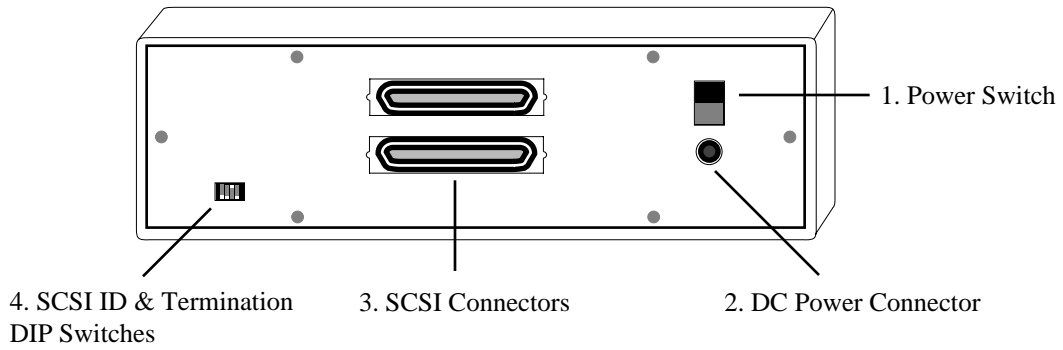

Figure 2.2 - Mindset Rear View

Feature

Description

1. Power Switch

Turns Mindset off and on.

2. DC Power Connector

Jack for connection to the DC power supply.



Never connect any other power supply or other device to this connector. Doing so will void your warranty and may result in serious injury or equipment damage.

3. SCSI Connectors

Connects Mindset to your computer and possibly to other devices in the SCSI chain.

4. SCSI ID & Termination

DIP style switches used to set Mindset's SCSI ID number and to select termination power.

Typical Mindset Connection

Figure 2.3 illustrates typical connections between Mindset, a power source, a computer, a montage selector and an electrode system are shown. Your specific configuration may be quite different.

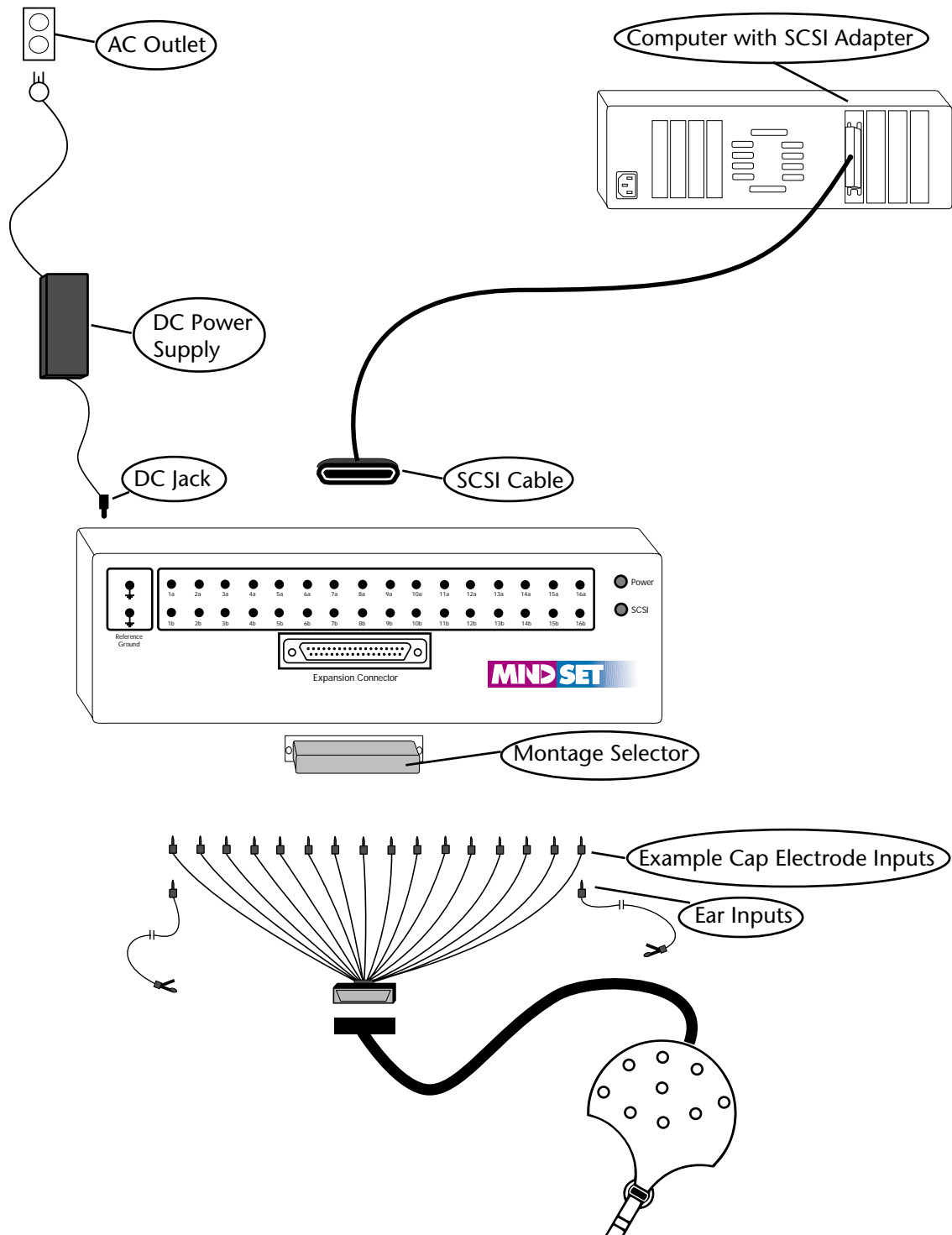

Figure 2.3 - Typical Mindset Connection

Connecting Mindset to Your Computer

Step 1 - Position the Mindset MS-1000

Find a level, flat, solid surface on which to place the unit. Place the unit away from sources of 60Hz electrical noise such as computer monitors, power supplies and florescent lighting to reduce the risk of 60Hz contamination in your EEG data.

Step 2 - Connect the Power Cable

Power off all of your computer equipment and Mindset.



Turn off power to Mindset, to your computer and to all devices on the SCSI chain before making any modifications to the SCSI bus.

Connect the power supply to the back of Mindset as previously illustrated. Plug the power supply's three prong power plug into an appropriate grounded power receptacle, preferably with surge and spike protection.



Never operate Mindset in an ungrounded power outlet or in a power outlet shared with heavy-load equipment such as photocopiers, fans, air-conditioners, laser printers, or large computer monitors.

Step 3 - Connect the SCSI Cable

Connect the SCSI cable to your computer's SCSI port. Then connect the remaining 50 pin end to the back of Mindset in either the top or bottom 50 pin connector. These two connectors are functionally identical and the open connector can be used for adding more SCSI devices or for termination (more on termination below).



*Mindset amplifies EEG signals up to 32,000 times, so it is **very** sensitive to electrical noise. One potential source of noise is your computer's SCSI bus. SCSI adapters (particularly PC Card notebook SCSI adapters) and other SCSI devices may be a source of noise. Please refer to the section on Achieving Good Recordings for more details.*

SCSI devices are physically connected together by cables in a *daisy chain*. When we refer to first or last devices, we refer to the physical location of the device within the daisy chain rather than the SCSI identification number (ID) of the device.

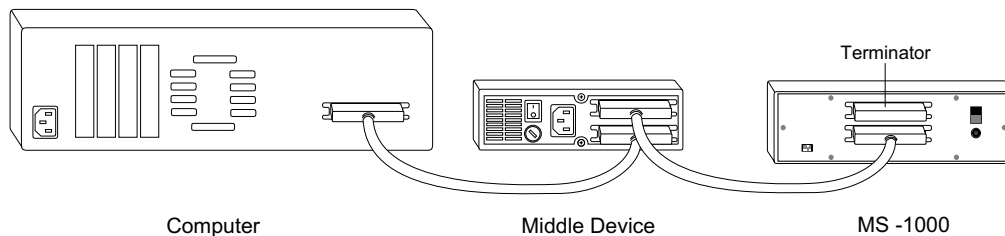

Figure 2.4 - SCSI Daisy Chain

Step 4 - SCSI Termination

The SCSI interface specifications permit up to seven peripheral devices to be connected to one host device. The first and last devices on the chain must have terminating resistors installed. Terminating resistors can be implemented in many different ways. NCS has supplied a small rectangular 50 pin terminator block that plugs into one of the two 50 pin SCSI connectors on the back of Mindset.

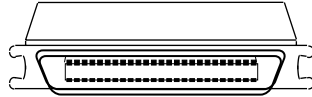

Figure 2.5 - SCSI Terminator Block

In addition to termination resistors, Mindset is able to supply termination power to the SCSI bus. In most cases, Mindset's termination power should be enabled when the termination block is installed and disabled when the termination block is not installed.

When deciding if you need to use the terminator block and Mindsets SCSI termination power, use the following as a guide:

<u>Situation</u>	<u>Terminator & Termination Power</u>
Mindset is the only SCSI device connected to the computer.	ON
Mindset is the second of two SCSI devices connected to the computer.	ON
Mindset is the last SCSI device in a chain of three or more devices.	ON*
Mindset is <i>not</i> the first or last device in a chain of three or more devices.	OFF

* In this case, make sure that none of the *middle* devices are terminated. Only the first and last devices should be terminated.



Your computer may have a SCSI peripheral (e.g., hard disk drive, CD-ROM drive) device inside its case. Refer to your computer's users manual to identify if there is an integrated SCSI peripheral device. If you do have a SCSI peripheral device either inside or connected to a SCSI bus on your computer, then you must identify its SCSI ID number and determine if it is terminated.

STEP 5 - SCSI ID Selection Switch

Each device connected to your computer's SCSI interface must have a unique SCSI identification number. The eight possible identification numbers are 0 through 7. SCSI ID number 7 is usually reserved for the host, so select SCSI ID numbers 0 to 6. When you select a number for Mindset, be certain that no other SCSI device has the same SCSI ID including any internal or tabletop devices already attached to your system.

Refer to the illustration and table below to set Mindset's SCSI ID and termination power option. Use a jeweler's screwdriver or a straightened paper clip to change the switches.

Once the switches are set correctly, you do not have to change them again unless you change your SCSI bus configuration. Mindset reads its own SCSI ID each time power is applied, so it is necessary to power Mindset off and on following a SCSI ID change.

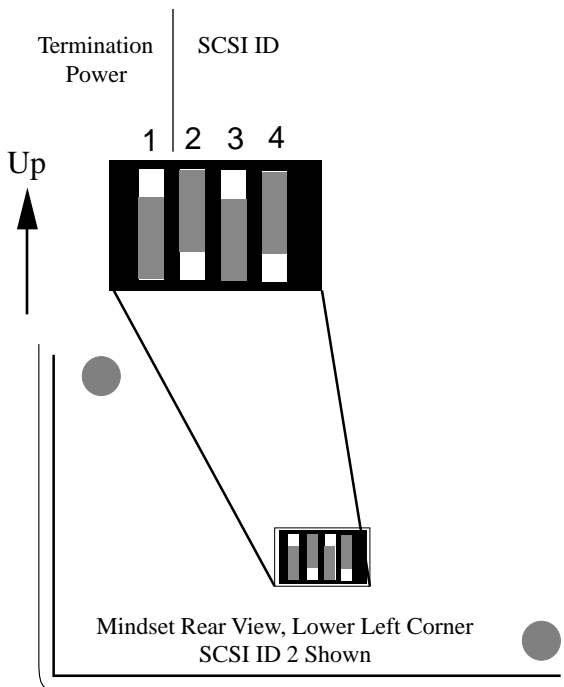

Table 2.1 - DIP Switch Settings

Switch 1 - Termination Power. Default position is up (off). To activate termination power, position the switch down.			
<u>SCSI ID</u>	<u>Switch 2</u>	<u>Switch 3</u>	<u>Switch 4</u>
0	down	down	down
1	up	down	down
2	down	up	down
3	up	up	down
4	down	down	up
5	up	down	up
6	down	up	up
DO NOT USE	up	up	up

Figure 2.6 - DIP Switch Location

Step 6 - Power Up Mindset

Ensure that you have:

1. A good location for Mindset.
2. The Mindset off and the power cord connected.
3. The SCSI cable is connected to both your computer's SCSI adapter and Mindset.
4. Termination is used, if necessary.
5. The SCSI ID# is set correctly.

Power up Mindset. Mindset's power switch is on the rear left side of the enclosure. The red power light should come on and the yellow SCSI light should flash briefly.

It is a good idea to turn on all of the external SCSI devices before switching on your computer.

Step 7 - Power Up Your Computer (Final Step)

When you boot your computer for the first time after connecting the Mindset hardware or after making any change to your SCSI adapter, you may see one of the following dialogs:

Using Windows 95 4.00950a Release

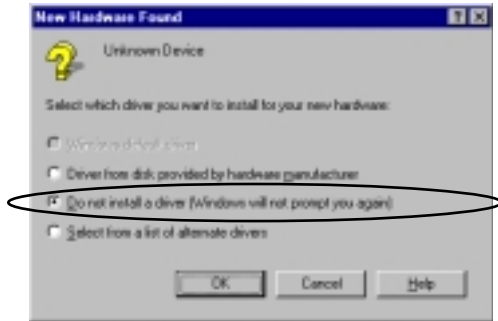

Using Windows 95 4.00950b (aka OSR2) Release

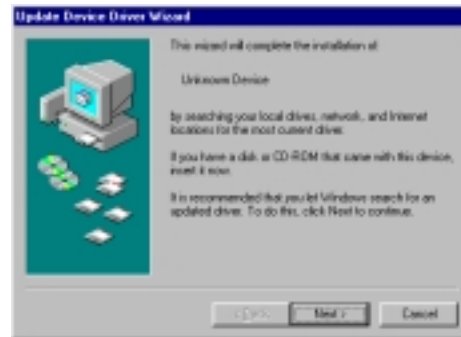

This indicates that the operating system has located Mindset on the SCSI bus.

If you are using Windows 95 4.00950a, select the “Do not install a driver (Windows will not prompt you again)” option.

If you are using Windows 95 4.00950b (aka OSR2), press the Next button. Windows searches for, but does not find a driver. This is as it should be. Press the Finish button.

As Mindset does not install a SCSI device driver in your system, Windows 95/NT considers it an unknown device. The above procedure instructs Windows to consider Mindset an other device in your System Properties, Device Manager Tab as shown below.

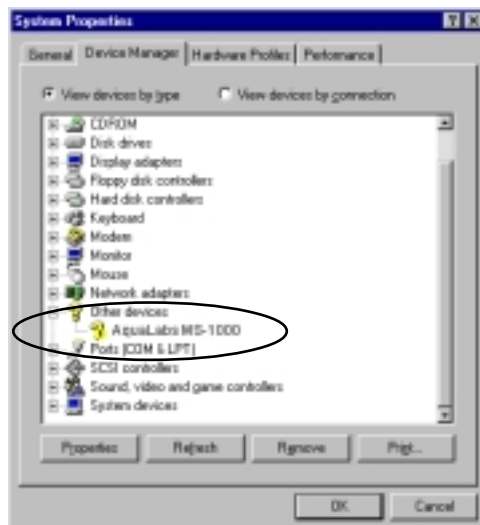

Figure 2.7 - System Properties, Device Manager Tab

Electrode Configuration

Mindset is designed to accommodate any electrode system that has input leads which terminate in 2mm pins. If your input leads terminate in female *safety* sockets, adapters are available from most electrode system manufacturers and resellers who carry EEG supplies.



NCS accepts no liability for hazards which might arise from improper use of your electrode system. Exercise extreme care in handling all connections to human subjects, including electrodes and grounding straps. Follow all guidelines provided by the manufacturer of your electrode system. If you are unsure about any connection to a human subject, stop and seek proper guidance. Do not attempt to defeat any safety measures which may be integral to your electrode system. Do not construe the instructions in this manual to suggest practices that may allow any part of the electrode assembly to come into contact with a source of dangerous electrical potential while a subject is connected.

Connection between EEG leads and ear clip leads to Mindset is accomplished through the front panel, as shown below:

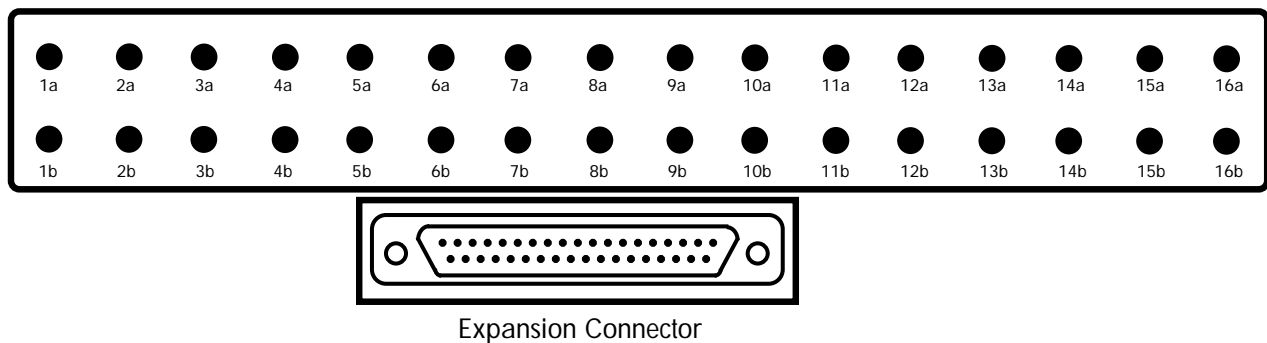

Figure 2.8 - Mindset Front Panel, Electrode Input Section

All 16 Mindset EEG channels have an “a” and “b” input. The differential amplifiers within Mindset amplify the difference between the “a” and “b” inputs to create the EEG data which is sent to your computer.



Please consult another source for general information on EEG systems design, common-mode rejection and other general aspects of EEG signal amplification.

Using the International 10-20 standard for electrode placement (illustrated below), consider the following figure:

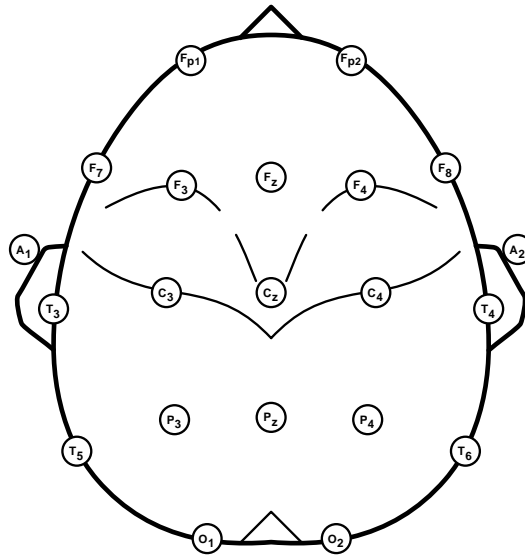

Figure 2.9 - International 10-20 Standard

Channel 1a is connected to Fp1 and channel 1b is connected to Fp2. The signal that would be sent to your computer on channel 1 would be the difference between Fp1 and Fp2. This is represented in EEG nomenclature as Ch 1 = Fp1-Fp2.

One standard configuration (or montage) for EEG neuromapping is known as *linked-ear referential*. *This is Mindset's default neuromapping montage.* In a linked-ear referential montage, all channels' "b" inputs are connected to ear clip positions A1+A2. This is accomplished by connecting the included Linked-Ear B Inputs montage selector to the Expansion Connector on the Mindset front panel. Doing so ties each channel's "b" input together. By inserting the input jacks from your electrode system's ear clip leads into any two "b" inputs, you tie each channel's "b" input to A1+A2.



If your electrode system utilizes mastoid references, simply connect the input jacks from those leads into any two "b" inputs, with the Linked-Ear B Inputs montage selector in place.

If you are using an Electro-Cap with Mindset, refer to Appendix IV for additional information.

The default neuromapping connection between Mindset’s input channels and the 10-20 standard electrode positions is as follows:

Table 2.2 - Standard 10-20 Electrode Positions

<u>Channel</u>	<u>“a” input</u>	<u>“b” input</u>
1	Fp1	A1+A2
2	Fp2	A1+A2
3	F7	A1+A2
4	F3	A1+A2
5	F4	A1+A2
6	F8	A1+A2
7	T3	A1+A2
8	C3	A1+A2
9	C4	A1+A2
10	T4	A1+A2
11	T5	A1+A2
12	P3	A1+A2
13	P4	A1+A2
14	T6	A1+A2
15	O1	A1+A2
16	O2	A1+A2

This default connection is provided for convenience only. The Mindset MS-1000 has 16 channels, so 3 of the 10-20 electrode positions are unconnected. In this default configuration, Fz, Cz, and Pz are not connected. You may chose to connect any of the 10-20 electrode positions to any Mindset input channel. If you differ from this default, however, you must instruct the Mindset software that you have done so (this is covered in the software reference section).

Mindset does not provide a user accessible point to connect to earth ground. If you intend to use your electrode system’s grounding point, you have to connect this lead to earth ground. Remember to follow all guidelines provided by the manufacturer of your electrode system. If you are unsure about any connection to a human subject stop and seek proper guidance. See the section on “Achieving Good Recordings” for additional information on human subject earth grounding.



Never connect a human subject to an earth ground unless you are absolutely certain that the connection point is at earth ground potential! If you do connect a human subject to earth ground, through whatever means, you must assure that the subject does not come in contact with any source of electrical potential. Failure to comply with these warnings can expose the human subject to harmful and even fatal electrical current!

Electrode Impedance Checking

The electrode impedance should be minimized in accordance with instructions provided with your specific electrode system. Use of an electrode impedance meter ensures that each electrode is making proper contact with the subject’s skin.

Chapter 3: Achieving Good Recordings

You must refer to other sources for general EEG information, description of proper EEG recording techniques, and for detailed discussion of EEG artifacts. A general knowledge of EEG is essential to obtaining valid data. Please read the Electrode Configuration Section of this manual before attempting EEG recording.

Techniques to Obtain the Best EEG Recordings with Mindset

Follow these steps to obtain the best EEG recordings when using Mindset:

1. Assure proper electrode impedance values for your electrode system.
2. Restrict movement of the subject while recording. Using a rolled towel to support the subject's neck will minimize head movement.
3. Watch the maximum amplitude of the input signal. If the amplitude exceeds 120 microvolts peak (or 240 microvolts peak-to-peak), the amplifiers will saturate and the resultant data is clipped and invalid.

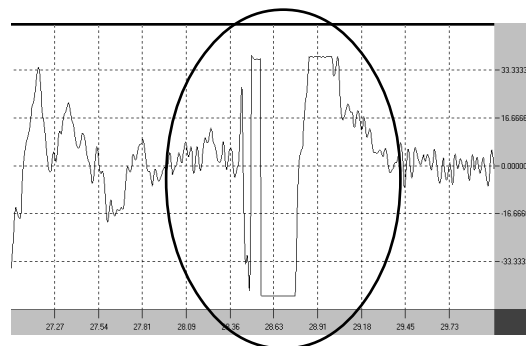

Figure 3.1 - Amplifier Saturation



If you need to extend Mindset's amplitude range, contact your distributor about the optional gain variance modules.

Minimizing Artifact Data Contamination

EEG data must be free of artifact for meaningful analysis to be possible. It is vitally important that you take careful steps to minimize artifacts before recording.

This section of the manual addresses specific steps which may be taken to reduce or eliminate common sources of artifacts when using Mindset. Each type of artifact described below may occur in one, a group, or all of the Mindset channels.

1. EKG

In some cases, the ear-clip electrodes which are supplied with several electrode systems can make electrical contact with the skin under the subject's ears. When this happens, an EKG artifact may become noticeable in several Mindset channels. A sinus rhythm, as shown below, may be evident in the data.

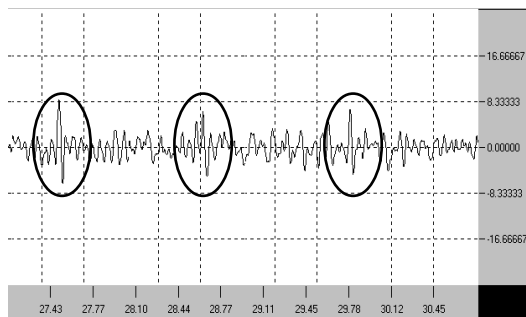

Figure 3.2 - EKG Artifact Displayed in WaveLab

Placing a cotton ball behind the subject's earlobes corrects the situation. A mastoid electrode substituted for the earlobe lead is also effective.

2. Muscle and Movement

Muscle impulses and subsequent movement which may effect electrode contact greatly degrades your EEG recordings. Try to restrict your subject's movement while recording.

3. Static Charges

It is possible, particularly in cold, dry climates, for static charges to build up on the subject. Small charges may cause slewing of the recorded EEG waveforms, while large charges may cause a popping affect in the data. The best preventative measure is to have your subject (and anyone else in the area) avoid movement which may cause friction, such as shuffling stocking feet across a carpeted floor. If the problem persists, spray the general area in which you operate Mindset with a commercial antistatic product. Subject earth grounding, described in the following section, also helps eliminate static artifacts.



Observe all warnings pursuant to grounding a human subject.

Electrical Noise Considerations

Since Mindset amplifies EEG signals up to 32,000 times, it is *very* sensitive to electrical noise. While careful design measures were taken to isolate Mindset from ambient noise, it is possible in extreme circumstances that electrical noise may contaminate the EEG data. In almost every case, making minor changes in your SCSI configuration, reorienting Mindset's power supply connection to AC, or connecting your subject to a solid earth ground should remedy the contamination.

1. SCSI Noise

One potential source of noise is your computer's SCSI bus. SCSI adapters (particularly PC Card notebook SCSI adapters) and other SCSI devices can be a source of noise. This noise is manifest as 8, 16, 24, or 32 Hz harmonic interference depending on Mindset's sampling rate. This harmonic interference is seldom seen to rise above the background noise in an unconnected channel. In other words, this contamination is so slight that it can only be seen when no actual input signal is on the channel. The following illustration shows this noise:

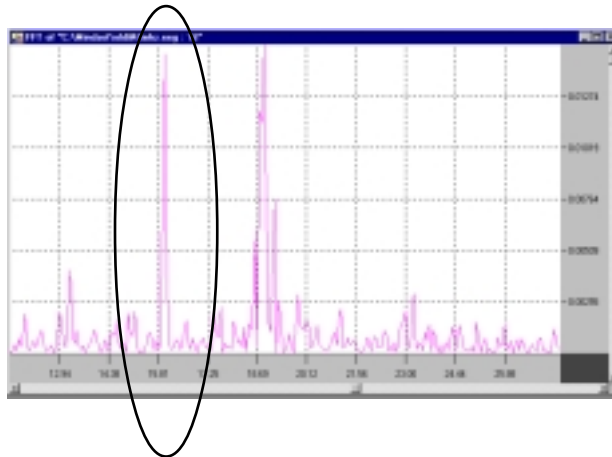

Figure 3.3 - 16Hz Harmonic Interference Shown in a WaveLab FFT

The above signal was generated using a particular PC card notebook SCSI adapter which draws power for its own internal terminating resistors from Mindset. In doing so, it generates a great deal of noise which radiates out from the SCSI chain and intrudes upon Mindset's inputs. This is the only known situation where the SCSI noise has been observed. The amount of noise seen in this situation is about .07 microvolts. While this is not a significant issue of contamination, it can be eliminated by using another PC card SCSI adapter.

It is possible that other SCSI devices could induce similar noise contamination. If you observe any suspect noise in spectral analysis of data from unconnected Mindset channels, removing the offending device from the SCSI device chain and/or removing the termination block and disabling termination power in Mindset should eliminate the problem. Refer to Appendix V for further discussion of SCSI noise.

2. AC Induced Noise

As previously noted, Mindset should never be operated in an ungrounded power outlet or in a power outlet that is shared with heavy-load equipment such as photocopiers, air-conditioners,

fans, laser printers, or large computer monitors. Such devices can cause glitches in a building's entire power distribution system and affect EEG data even if Mindset is not sharing a power outlet with them. Filtered power strips (line filters) with surge and spike protection can help prevent these transient glitches from appearing in your data. If you detect consistent popping glitches in the waveform data from Mindset, it may be necessary to connect Mindset's power supply to another leg of your building's main power transformer. This measure is rarely called for, however.

3. Subject Ground - 50 or 60Hz Induced Noise

In environments with high levels of 60Hz (or 50Hz) electrical noise emanating from florescent lighting fixtures, laboratory equipment, computer equipment, or other noisy equipment, the levels of 60Hz riding on your subject's body may exceed Mindset's high levels of 60 Hz filtration. Figure 3.4 illustrates 60Hz contamination in a Mindset channel.

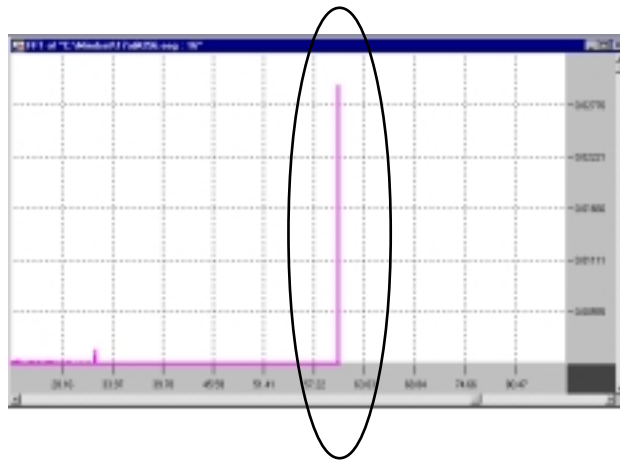

Figure 3.4 - 60Hz Noise Shown in a WaveLab FFT

In this situation, it may become necessary to connect your subject to earth ground using an appropriate grounding strap or grounding point provided in your electrode system. This should bleed off the 60Hz noise.



Mindset does not provide a user accessible point to connect to earth ground. If you intend to use your electrode system's grounding point, you have to connect this lead to earth ground. Remember to follow all guidelines provided by the manufacturer of your electrode system. If you are unsure about any connection to a human subject, stop and seek proper guidance.



Never connect a human subject to an earth ground unless you are absolutely certain that the connection point is at earth ground potential! If you do connect a human subject to earth ground, through whatever means, you must assure that the subject does not come in contact with any source of electrical potential. Failure to comply with these warnings can expose the human subject to harmful and even fatal electrical current!

Appendix I - Support and Service

Customer Support

The best source of Mindset support is your distributor. Technical questions and issues may also be e-mailed to nolanw19@idt.net. Please consult this manual before calling for technical support.

Developer Support

NCS is committed to supporting developers and end-users who wish to add functionality or create custom applications for Mindset. Please contact Nolan Computer Systems at nolanw19@idt.net for more information.

Product Service

Should your Mindset MS-1000 require service, contact nolanw19@idt.net for return authorization. Electrode systems are warranted through their original manufacturer. Contact your electrode system manufacturer with any questions or service requirements specific to their products.

Mindset is warranted to be free from defects which effect proper operation for a period of one year from the date of sale. Units returned for in-warranty service must be accompanied by a copy of the bill-of-sale. Please refer to the Mindset Hardware Warranty for more information.

MINDSET HARDWARE WARRANTY

LIMITED HARDWARE WARRANTY. NOLAN COMPUTER SYSTEMS (NCS) warrants the MINDSET hardware against defects in material or workmanship as follows:

1. Labor: For a period of one (1) year from the original date of purchase from NCS or its local representative supplier, NCS will repair defects in MINDSET at no charge or pay the labor charges to any NCS authorized service facility. After this 1 year period, you must pay for all labor charges.

2. Parts: For a period of one (1) year from the original date of purchase from NCS or its local representative supplier, NCS will supply, at no charge, new or rebuilt replacement parts (at its discretion) in exchange for defective parts of MINDSET. Any replacement parts will be warranted for the remainder of the original warranty period or ninety (90) days from installation by NCS's authorized service facility, whichever is longer. All exchanged parts replaced under this warranty will become the property of NCS.

This warranty extends only to the original purchaser. It is not transferable to anyone who subsequently purchases MINDSET from you.

Proof of purchase in the form of a copy of the bill-of-sale (which is evidence that MINDSET is within the warranty period) must be presented to obtain warranty service.

Be sure to remove all features, parts, options, alterations, and attachments not under warranty prior to returning MINDSET to NCS. NCS is not liable for any loss or damage to these items.

This Limited Warranty does not cover any consumable items supplied with MINDSET, cosmetic damages, damage or loss to any software programs, data, or removable storage media, or damage due to:

- (1) acts of God, accident, misuse, abuse, negligence, commercial use or modifications of MINDSET
- (2) improper operation or maintenance of MINDSET
- (3) connection to improper voltage supply
- (4) attempted repair by any party other than an NCS authorized service facility.

This Limited Warranty does not apply when the malfunction results from the use of MINDSET in conjunction with accessories, products, or ancillary or peripheral equipment, or where it is determined by NCS that there is no fault with MINDSET itself. This Limited Warranty is invalid if the factory applied serial number has been altered or removed from MINDSET.

REPAIR OR REPLACEMENT AS PROVIDED UNDER THIS WARRANTY IS THE EXCLUSIVE REMEDY OF THE CONSUMER. NCS SHALL NOT BE LIABLE FOR ANY INCIDENTAL OR CONSEQUENTIAL DAMAGES FOR BREACH OF ANY EXPRESS OR IMPLIED WARRANTY, BREACH OF CONTRACT NEGLIGENCE, STRICT LIABILITY OR ANY OTHER LEGAL THEORY RELATED TO MINDSET. SUCH DAMAGES INCLUDE, BUT ARE NOT LIMITED TO, LOSS OF PROFITS, LOSS OF REVENUE, LOSS OF DATA, LOSS OF USE OF MINDSET OR ANY ASSOCIATED EQUIPMENT, DOWN TIME AND PURCHASER'S TIME. EXCEPT TO THE EXTENT PROHIBITED BY APPLICABLE LAW, ANY IMPLIED WARRANTY OF MERCHANTABILITY OR FITNESS FOR A PARTICULAR PURPOSE ON MINDSET IS LIMITED IN DURATION TO THE DURATION OF THIS WARRANTY.

Some states do not allow the exclusion or limitation of incidental or consequential damages, or allow limitations on how long an implied warranty lasts, so the above limitations or exclusions may not apply to you. This warranty gives you specific legal rights and you may have other rights which vary from state to state.

Appendix II - Cleaning Mindset



Turn off and unplug Mindset before cleaning.

Do not spill liquid on Mindset. Do not under any circumstances allow liquid to touch the input jacks or the Expansion Connector.

The MS-1000 enclosure should be cleaned with a water dampened cloth only. If any evidence of corrosion is evident in the front input jacks or Expansion Connector, they may be cleaned only with a commercial electronic contact cleaner. Follow the guidelines provided with the commercial product.

Appendix III - Specifications

MS-1000 Hardware

Specifications are typical and are subject to change without notice.

1. Channels

16 differential input channels (32 input jacks)
90 dB amplifier gain, 60dB signal to noise ratio

2. Resolution

16 bit analog to digital converter
64 to 1024 samples/second/channel

3. Filtration

Two fourth-order Sallen-Key active filters, 48bd roll-off per octave
2.8Hz - 33 Hz frequency pass band @ -3 dB (1.8Hz - 35Hz @ -6 dB)

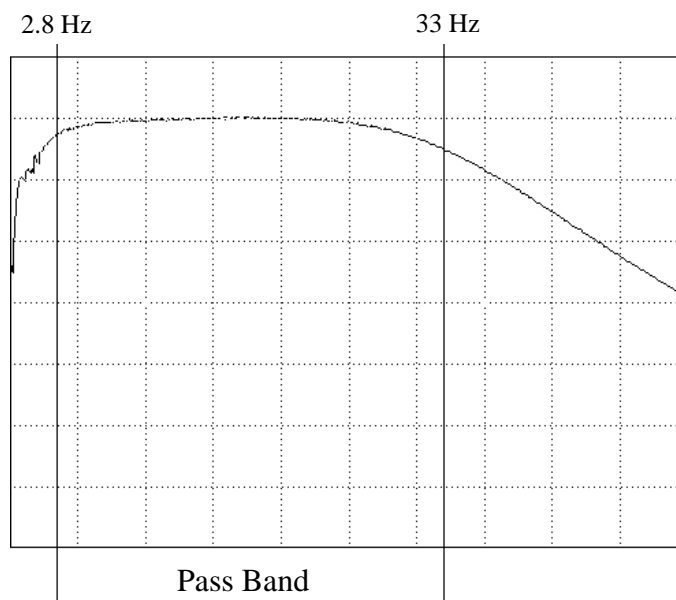

4. Common Mode Rejection

120bd maximum, 87dB typical in pass band

5. Input Range

0 - 120 microvolts (μV) peak, 0 - 240 μV peak-to-peak

6. Electrodes

Standard electrode inputs (compatible with Electro-Cap and e-Net)

7. Montage Reference Configuration

User selectable through Expansion Connector
Linked-Ear Referential module supplied

8. Expansion Connector Pinout

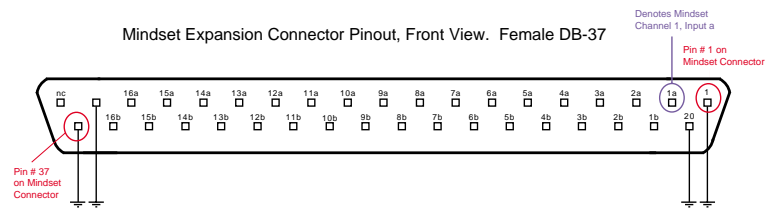
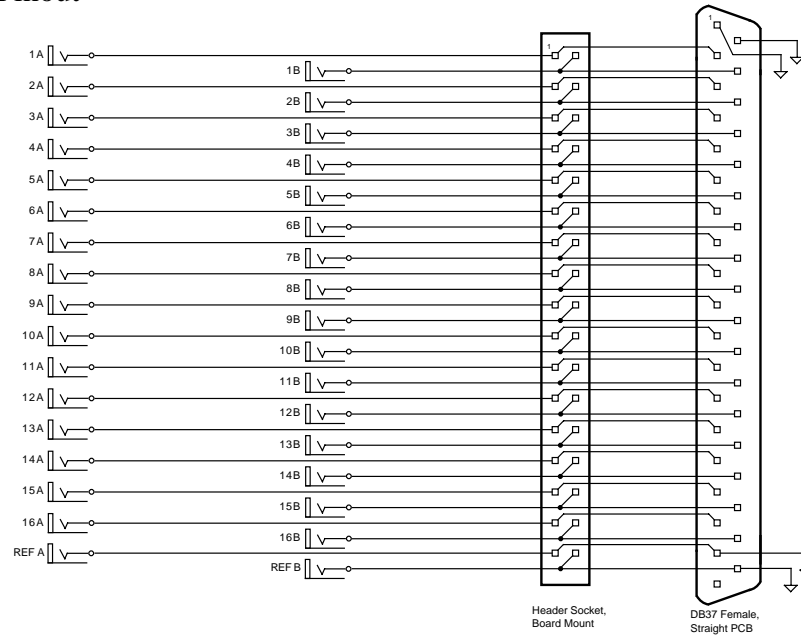

9. Interface to Computer

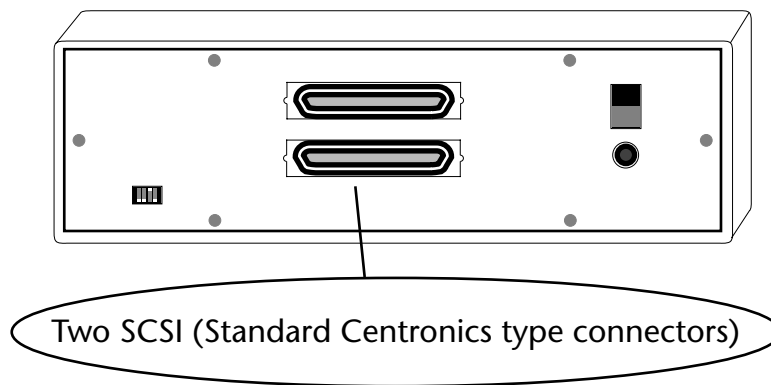

10. Opto-Isolation

2500 volts RMS

11. Total Harmonic Distortion

-87dB

.01% opto-isolator servo linearity

12. Calibration

Factory calibrated*, automatic and user calibration via software
(*optional calibration certificate available)

13. Power

Input Voltage: 90 - 264 VAC

AC Input Frequency: 47 - 63Hz

Switching Frequency: 50KHz (typical)

Power Consumption: 15 watts

14. Operational Temperature

32°F - 90°F, do not operate in direct sunlight

15. Dimensions and Weight

13" deep, 11.31" wide, 3.88" high

Main unit - 7 pounds, external power supply - 8.3oz

Appendix IV - Electro-Cap Users

Using the Electro-Cap with Mindset MS-1000



NCS accepts no liability for hazards which might arise from improper use of your electrode system. Exercise extreme care in handling all connections to human subjects, including electrodes and grounding straps. Follow all guidelines provided by the manufacturer of your electrode system. If you are unsure about any connection to a human subject, stop and seek proper guidance. Do not attempt to defeat any safety measures which may be integral to your electrode system. Do not construe the instructions in this manual to suggest practices that may allow any part of the electrode assembly to come into contact with a source of dangerous electrical potential while a human subject is connected.

Additional Information for Electro-Cap Procedures

Complete all steps as specified in the Electro-Cap manual for to attaching the body harness, attaching the cap, and preparing the electrode sites. Refer to the following illustrations as an aid in connecting the Electro-Cap to the Mindset.



Your Electro-Cap Electrode Board Adapter wires may need to be separated two inches further in order for all pins to reach the MS-1000 input jacks without tension. Separate the wires carefully and evenly. The wires should never, under any circumstances, be separated back to the blue connector.

Mindset Standard Neuromapping Montage Wiring

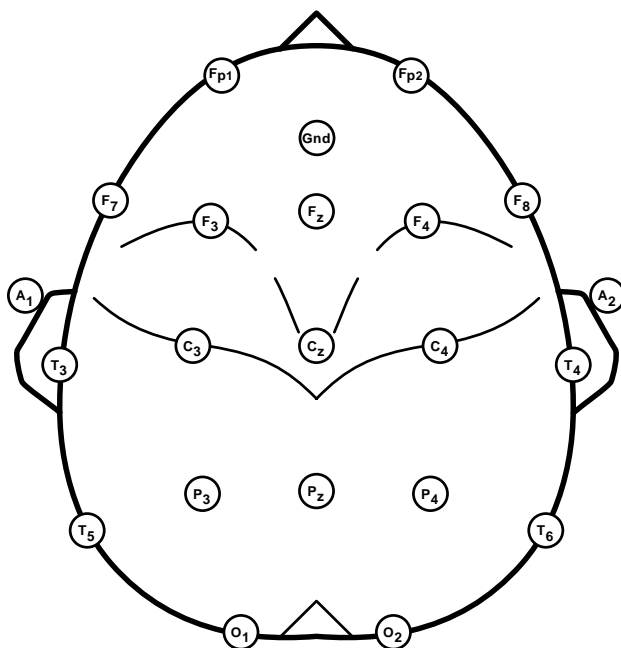
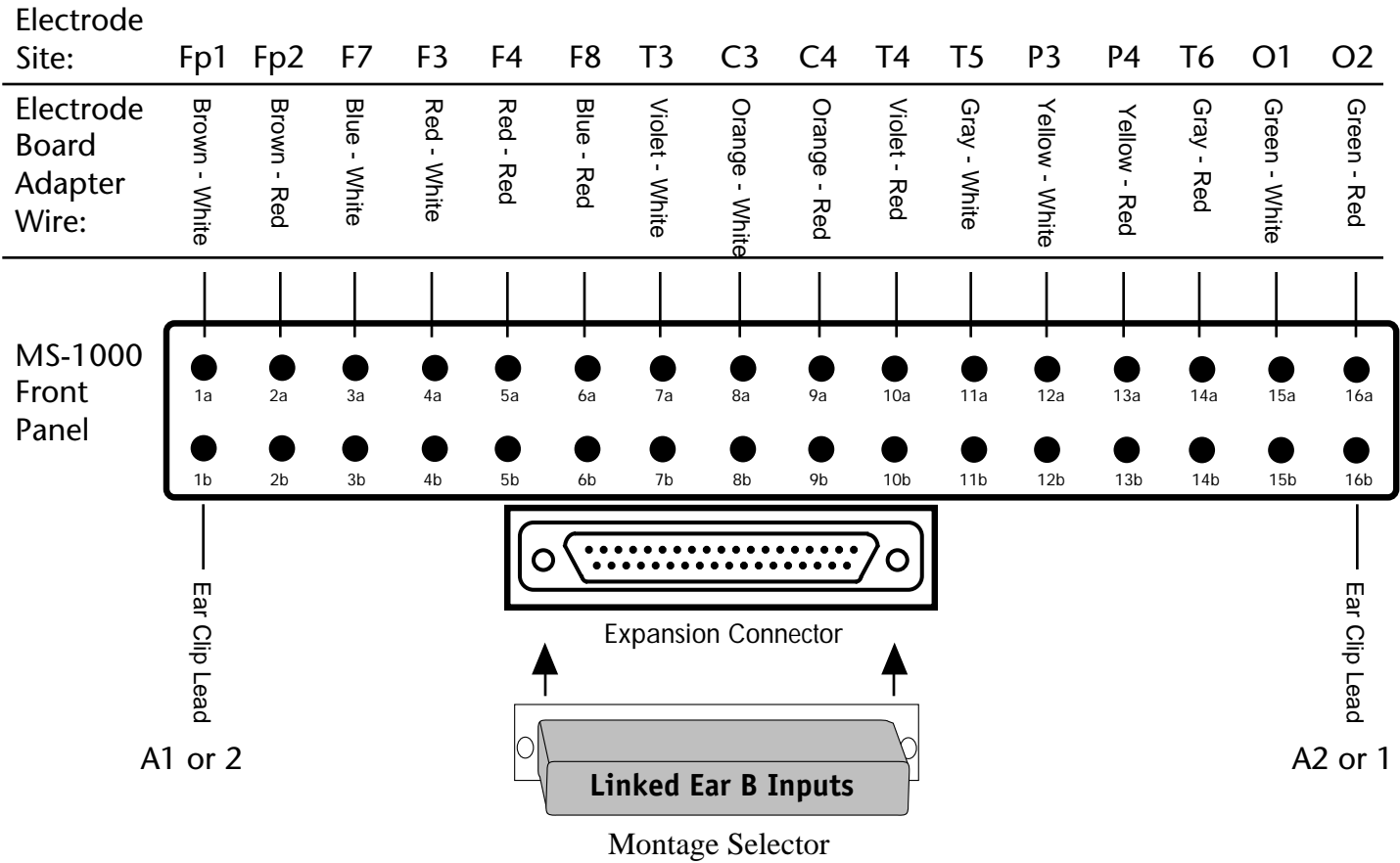

Electro-Cap Pinout		
White Tip	Wire Color	Red Tip
Fp1	Brown	Fp2
F3	Red	F4
C3	Orange	C4
P3	Yellow	P4
O1	Green	O2
F7	Blue	F8
T3	Violet	T4
T5	Gray	T6
Gnd	White	Cz
Fz	Black	Pz

Subject Earth Ground

Mindset does not provide a user accessible point to connect to earth ground. If you intend to use your Electro-Cap's grounding point (Gnd), you must connect this lead to earth ground.



Never connect a human subject to an earth ground unless you are absolutely certain that the connection point is at earth ground potential! If you are unsure about any connection to a human subject, stop and seek proper guidance. If you do connect a human subject to earth ground, through whatever means, you must assure that the subject does not come in contact with any source of electrical potential. Failure to comply with these warnings can expose the human subject to harmful and even fatal electrical current!



See the section on Achieving Good Recordings for additional information the on topic of earth grounding.

Impedance Checking

The electrode impedance should be minimized in accordance with instructions provided with your specific electrode system. Use of an electrode impedance meter ensures that each electrode is making proper contact with the human subject's skin.

EKG Artifact

In some cases, the supplied ear-clip electrodes can make electrical contact with the skin under the subject's ears. When this happens, an EKG artifact may become noticeable in several Mindset channels. Placing a cotton ball behind the human subject's earlobes, after applying the Electro-Cap, should correct the situation.

Appendix V - Additional SCSI Issues

Background

The SCSI bus is a resistor terminated and high current bus. The termination resistors (or *block*) do two things:

- they help match the characteristic impedance of the SCSI bus wires to the input circuitry, thus preventing the signals from reflecting and ringing.
- termination power is applied through the resistors to pull the voltage on the wires up to at least 2.8 volts.

A high (2.8 to 5.0) voltage on the bus wires represents the *inactive* or zero state. A signal is driven active by driving the voltage to below 0.7 volts.

Without termination power, all of the wires on the bus would remain at zero volts and no communication would be possible. Without termination resistors, signals on the bus are not at their proper voltages and can cause ringing and unreliable operation. Therefore, both termination power and termination resistors are necessary. Most SCSI devices are designed to provide termination power, including Mindset.

Unfortunately, high current on the SCSI bus leads to strong magnetic fields being generated. These magnetic fields in turn create voltages in wires that they cross. Mindset's amplifiers are very sensitive and can pick up these minute signals. The goal is to minimize these signals.

Noise Intrusion

Depending upon several factors (such as sample rate, SCSI bus termination, SCSI bus configuration, etc.), it is possible for SCSI bus noise to intrude upon EEG data. This noise usually shows up as a spurious 2, 4, 8, 16 or 32 Hz signal. This is because MindLab may be transferring data from the Mindset hardware at these intervals and the SCSI bus has heavy activity then.

The noise is best seen by taking a minute or two of data without any connections to Mindset's front panel. If you observe such noise, try setting the block size to a smaller value (refer to the software manual for instructions). This forces MindLab to access Mindset at a higher rate (because the same amount of data is transferred each second). The idea is to make this access rate higher than 32 Hz, moving it out of Mindset's passband.

For example, assume you are sampling at 256 sps and the SCSI block transfer size is set to 512 bytes. Every second, there are 8,192 bytes of data transferred across the SCSI bus:

$$256 \text{ samples/second} * 2 \text{ bytes/sample} * 16 \text{ channels} = 8,192 \text{ bytes/second.}$$

Since MindLab grabs these data in 512 byte blocks (the SCSI block size), the access frequency from MindLab to Mindset is $8,192 / 512 = 16$ accesses per second. Under some circumstances this may show up as a spurious 16 Hz signal in the EEG data.

In the above case, if you were to reset the block size to 256 bytes, the access rate would be forced to double to 32 accesses per second, thus moving the noise signal to the upper end of the passband.

With some SCSI cards the noise is more pronounced. In general, if a SCSI card draws its termination power from Mindset, the noise is more likely to show up. It is always best to use Mindset as the only device on the SCSI bus chain. The SCSI card in your PC should be supplying the termination power. If this is the case, you can turn Mindset's termination power off and remove the termination block.

Below is a list of possible SCSI configurations. They are listed in order, from most quiet to most noisy.

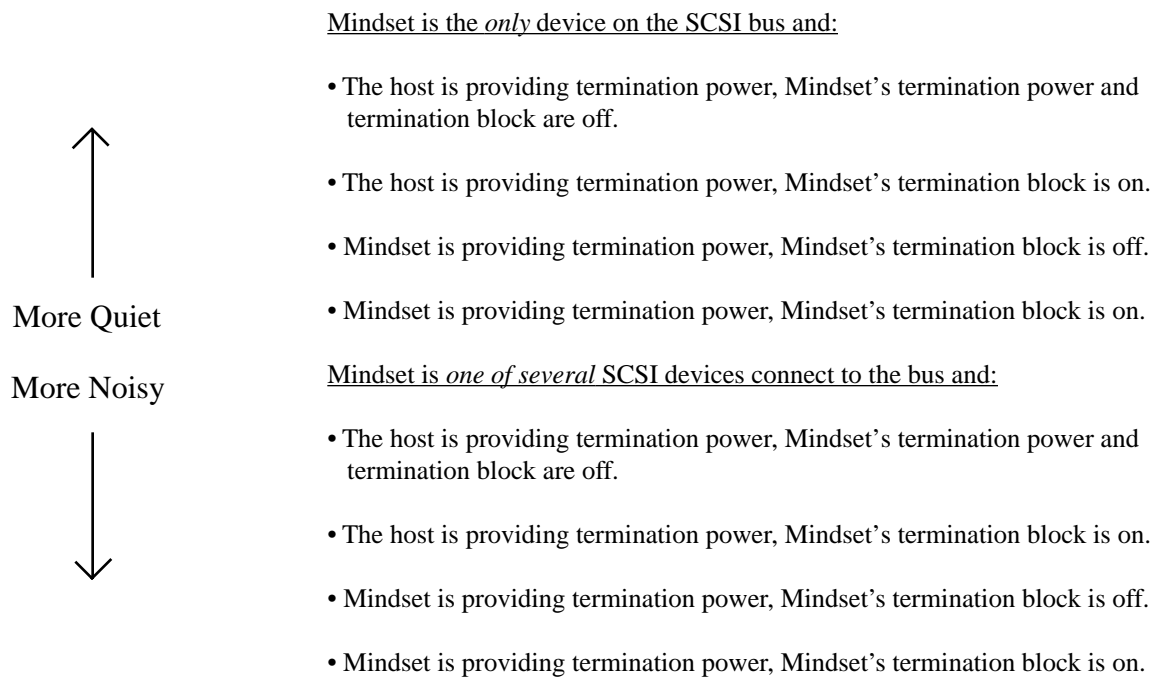

In most cases, if Mindset is the only device on the SCSI bus and the host is providing termination power, Mindset runs fine with its own termination power and termination block off. This configuration results in the least amount of noise intrusion.

For power conservation, some laptop computer SCSI cards do not provide termination power. Refer to the manual provided with your SCSI card. If possible, turn *on* the SCSI card's termination power and turn Mindset's *off*. If your card does not provide termination power, you must turn on Mindset's. You may have to experiment with various configurations to obtain the quietest and most reliable operation.